

**Eagle Scout  
Leadership Service  
Project Workbook**

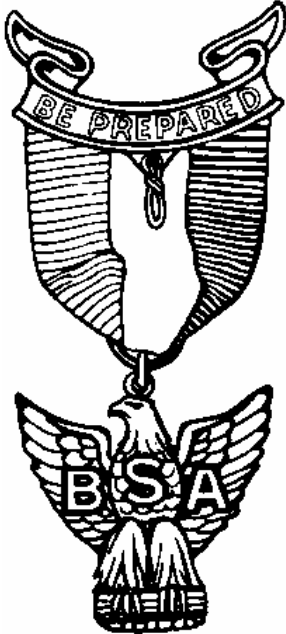

**Justin Lundstrom**

Scout's Name

**3708 Upland Dr. Marietta, Ga 30066**

Address

**770-565-6907**

**E-mail: Nemp91@yahoo.com**

Telephone no.

**Troop 714**

Unit No.

**Foothills District**

District

**Atlanta Area Council**

Local Council

**Ferrell Moultrie**

Unit leader's name

**4243 Cutter Ct. Ne, Roswell, Ga 30075**

Address

**770-552-0486**

Telephone No.

**Jerry Richstein**

Unit advancement committee person's name

**4798 Grants Way Ne Marietta, Ga 30066**

Address

**770-924-4779**

Telephone No.

# Project Description

---

## **Describe the project you plan to do.**

The proposed eagle project would involve the construction of handicap ramps in the front of the Christ United Methodist Church office. The ramps will be attached to the church office concrete porch. It will extend out roughly 8 feet and attach to a level landing. From the level landing it will turn 90 degrees to a series of ramps for 28 feet, sloping down to ground level. The bottom of the ramp will meet with the existing sidewalk. Slat-picket rails will be placed along the entire ramp and platform area. A hand railing will also be attached on one-side of the ramp.

A portion of the existing porch railing/fencing will be demolished and a portion of new railing/fencing will be added to cover up where the existing stairs attach to the porch.

The existing stairs will remain, but will no longer be used.

**What group will benefit from the project?**

This project will mainly benefit the physically handicapped in being able to access the front door of the main church office.

Christ United Methodist Church		(770) 993-3945	
Name of religious institution, school or community		Telephone No.	
1340 Woodstock Road	Roswell	Ga	30075
Street Address	City	State	Zip code

**My Project will be of benefit to the group because:**

At present the only access to the front door of the Christ United Methodist Church main church office is a set of old, steep, sinking brick steps that were constructed 40+ years ago when the building was built. The front door is not currently handicap accessible and is also a challenge for elderly individuals to navigate safely. By building this ramp to the porch where the front door is located, the main office will become a more inviting and easier place for anyone in the congregation and/or visitors to access.

This concept was discussed with my unit leader on 12/01/08  
Date

The project concept was discussed with the following representative of the group that will benefit from the project.

<u>Rev. Keith Lawder</u>	<u>11/17/08</u>
Representative's Name	Date of meeting
<u>Pastor</u>	<u>(770) 993-3945</u>
Representative's Title	Phone No.

# Project Details

## Present Condition

The entry to the front door of the church office building has old, steep, brick steps, which are sinking. These conditions make it very difficult for elderly and handicapped persons to have access to the main church office.

## Plans / Drawings / Designs

See framing plan - sheet 1, for a layout of the ramp modules and ramp railing design; and location of new porch railing.

See support plan – sheet 2, for supports used to hold up the ramp modules

## Materials

The lumber to build the ramps represents the major cost of this project. All of the items will be purchased from the local home center.

Some church members are contractors and may donate items for the project.

<b>Material</b>	<b>Provided By</b>	<b>Total Needed</b>	<b>Unit Cost (\$)</b>	<b>Total Cost (\$)</b>
3/4"x4'x8' treated plywood	purchase	1	27.97	27.97
5/4"x6"x8' treated decking	purchase	39	3.97	154.83
same - 10'	purchase	5	4.97	24.85
2"x2"x36" baluster spindles	purchase	187	0.89	166.43
2"x4"x8' treated	purchase	10	2.49	24.90
same - 10'	purchase	7	3.29	23.03
same - 12'	purchase	7	3.89	27.23
2"x6"x8' treated	purchase	14	3.57	49.98
same - 10'	purchase	28	4.97	139.16
4"x4"x8' treated	purchase	14	5.97	83.58
2"x6" joist hanger	purchase	42	0.68	28.56
10d 1-1/2" ext galvanized nails	purchase	736	0.06	41.13

3/8" x 4" carriage bolts	purchase	12	1.53	18.36
3/8" hex nuts and washers	purchase	12	0.42	5.04
1/2" x 10" carriage bolts	purchase	28	3.84	107.52
1/2" hex nuts and washers	purchase	28	0.69	19.32
1/2"x3" hex sleeve anchors	purchase	6	1.47	8.82
2.5" coated deck screws	purchase	872	0.11	98.50
3" coated deck screws	purchase	136	0.11	15.36
hand rail brackets	purchase	8	4.29	34.32
1-1/2" x 10' PVC pipe	purchase	140	0.49	68.18
1-1/2" PVC coupling	purchase	15	0.61	9.15
1-1/2" PVC elbow	purchase	8	1.20	9.60
PVC cement	purchase	1	5.96	5.96
4'x8' plastic lattice	purchase	1	12.50	12.50
1 gallon of white paint	purchase	1	18.00	18.00
Paint Brush	purchase	2	6.00	12.00
<b>Subtotal</b>				<b>1,234.28</b>
Contingency & sales tax (* 10%)				123.43
<b>TOTAL</b>				<b>1,357.71</b>

## Supplies

<b>Supplies</b>	<b>Provided By</b>	<b>Total Needed</b>	<b>Unit Cost</b>	<b>Total Cost</b>
Box of trash Bags	Justin Lundstrom	1	\$3.00	\$3.00
Package of 100 paper plates and paper cups	Justin Lundstrom	1	\$6.00	\$6.00
Pencils	Justin Lundstrom	10	\$.20	\$2.00
Sodas, water, and food for three Saturdays of work	Justin Lundstrom	3 sets	\$30/week	<b>\$90.00</b>
<b>Total cost of Purchased Supplies</b>				<b>\$101.00</b>

## Tools

All of the tools for this project will be from the Lundstrom house, or borrowed. I am going to ask church members and friends for tools that are listed as borrowed.

<b>Tools</b>	<b>Total Needed</b>	<b>Provided By</b>
Power Miter Saw with 10'' Blade	1	Lundstrom
Circular Saw with 7 1/4' Blade	1	Lundstrom
Hand Saw	2	Lundstrom-borrow
Block Plane	1	Lundstrom
Saw Horses	1	Lundstrom
3/8'' Variable Speed Reversible Drill	2	Lundstrom-borrow
1/2'' Variable Speed Reversible Drill	1	Lundstrom
12'' x 9/16 Twist Drill bit	3	Lundstrom-Borrow
3/8'' Twist Drill Bit	1	Lundstrom
1 -1/2 '' Fly Cut Drill Bit	1	Lundstrom
#2 Phillips 1/4'' Drive Bits	3	Lundstrom-borrow
#3 Phillips 1/4'' Drive Bits	3	Lundstrom-borrow
Deck screw drive bit	2	Lundstrom
Cordless Drills – VSR	2	Lundstrom-borrow
Post Level	2	Lundstrom-borrow
2' level	2	Lundstrom-borrow
4' level	2	Lundstrom-borrow
String Level	1	Lundstrom
String Line	1	Lundstrom
Framing Square	1	Lundstrom

25'x1'' Tape Measure	1	Lundstrom
50'x1'' Tape Measure	1	Lundstrom
Sledge Hammer	1	Lundstrom
Spade or Shovel	2	Lundstrom-borrow
Post hole Digger	1	Lundstrom-borrow
Rake	1	Lundstrom
Claw Hammers	6	Lundstrom-borrow
Vice Grip	1	Lundstrom
3/8'' Ratchet Driver	2	Lundstrom
9/16''x3/8 Deep Socket	1	Lundstrom
3/4''x3/8'' Deep Socket	1	Lundstrom
8'' Adjustable Wrench	1	Lundstrom
25' Power Cords – grounded	3	Lundstrom-borrow
Safety Goggles	4	Lundstrom-borrow
Safety Face Masks	1	Lundstrom-borrow
Bumper Jacks	2	Lundstrom-borrow
First Aid Kit	1	Lundstrom

## **Step-by-step instructions**

This project will be done in phases with multiple steps in each phase. The main steps include:

- 1) Purchase materials and prepare site
- 2) Remove and discard landscaping; and existing porch railing where ramp will be installed
- 3) Assembly of ramp modules
- 4) Assembly of landing module
- 5) Assembly of support structures
- 6) Assembling the modules into ramps
- 7) Installing railing pickets and top rails
- 8) Installing a section of railing on the porch

### **Design Requirements**

The existing porch is 36 inches above the elevation of the sidewalk.

ADA code requires ramp design to have a maximum slope of 1:12. Based on a 36 inch rise, the ramp must be at least 432 inches long. The design of the ramp is 432 inches long, plus a 58"x60" level platform in the middle of the ramp (not included in the ramp length calculation).

The ramp will be built to meet local building codes.

Some design ideas for the project came from <http://www.wheelchairramp.org/>

### **Purchase Materials and Prepare Site**

I will buy materials and supplies at the local Home Depot or Lowes and take them to the church. I will gather tools and take them to the church. We have a pick-up truck, so I can transport material and supplies to the church.

**Demolition**

Remove and discard the landscaping; and the porch railing/fence section that occupies the space where the top of the ramp is going to be located.

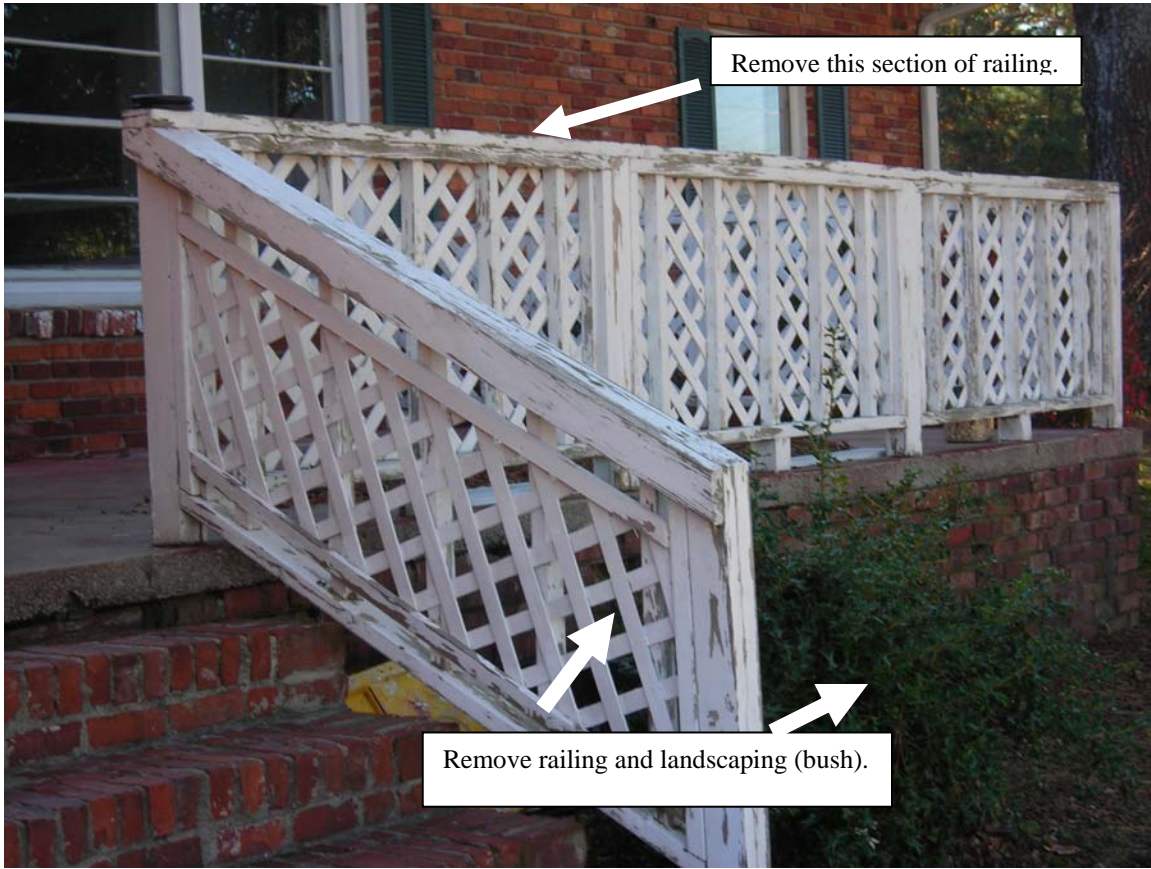

## **Assembly of Ramp Modules**

There will be three ramp modules built to 112"x 42"

There will be one ramp module built to 96"x 42"

### **Components for one 112"x42" module:**

- 4 – 2x6 by 112" joists (order four 2x6x10 and cut 4 joists)
- 2 – 2x6 by 42 end pieces (order one 2x6x8 and cut 2 end pieces)
- 1 – 2x6 by x" blocking (order one 2x6x8 then cut to length for blocking pieces between joists)
- 20 – 5/4" x 6" by 42" decking (order 10-8' section of decking and cut 2 pieces from each)
- 160 – 2 1/2" deck screws (8 per decking plank)
- 16 – 3" deck screws (to attach end pieces to joists)
- 18 – 3" deck screws (to attach blocking between joists)
- 8 – 2 x 6 joist hangers
- 64 – joist hanger nails (8 per hanger)

### **Components for one 96"x42" module:**

- 4 – 2x6 by 96" joists (order four 2x6x8)
- 2 – 2x6 by 42 end pieces (order one 2x6x8 and cut 2 end pieces)
- 3 – 2x6 by x" blocking (order one 2x6x8 cut to length for blocking pieces between joists)
- 17 – 5/4" x 6" by 42" decking (order 9 – 8' decking and cut 2 pieces from each)
- 136 – 2 1/2" deck screws (8 per decking plank)
- 16 – 3" deck screws (to attach end pieces to joists)
- 18 – 3" deck screws (to attach blocking between joists)
- 8 – 2x6 joist hangers
- 64 – joist hanger nails (8 per hanger)

### **Construction of ramp module (see sheet 1 drawing):**

1. Cut joists and end pieces to length and assemble on flat surface. Space joists 14" apart on center.
2. Screw end pieces to the ends of joists with 3" screws.
3. Insure module is square and nail on joist hangers.
4. Bend outside flange of four corner joist hangers flat against end pieces of module.
5. Decking will be attached after module frame is placed in a ramp.
6. Drill a 3/8" hole centered on the end pieces and drill two 3/8" holes 6" from each side. All three holes to be centered vertically on the end piece.

## **Assembly of Landing Module**

There will be one landing module, 58" x 60"

### **Components:**

- 5 – 2x6 by 55" joists (three 2x6x10 - cut five joists)
- 2 – 2x6 by 60" end pieces (one 2x6x10 - cut two end pieces)
- 10 – 5/4" by 60" decking (five 5/4"x6"x 10' cut into ten pieces)
- 100 – 2 1/2" deck screws (10 per decking plank)

20 – 2 ½” deck screws (to attach end pieces to joist)  
10 - 2x6 joist hangers  
80 joist hanger nails

**Construction of Landing Module (see sheet 1 drawing):**

1. Cut joists and end pieces to length and assemble on flat surface. Space joists 15” apart on center.
2. Screw end pieces to the ends of joists with 3” deck screws.
3. Insure landing is square and nail on joist hangers.
4. Bend outside flange of four corner joist hangers flat against end pieces of landing.
5. Decking will be attached after landing frame is placed in a ramp.
6. 3/8” holes to allow connection to ramp modules will be drilled at time of ramp construction.

**Assembly of Support Structures**

There will be five support structures for the ramp. See sheet 2 drawing for layout.

There will be two additional support pieces required for the landing platform

**Components for each ramp support structure (for supporting modules over 21” high):**

- 2 – 4x4 Support Posts (length determined by height requirements of ramp)
- 2 – 1’x1’ by ¾” treated plywood pads (will be screwed to bottom of 4x4 with three 3” deck screws)
- 2 – 2x6 by 49 ½” cross support
- 4 – 2x4 trimmers (length equals distance between bottom of cross support and plywood pad) (trimmer will be screwed to 4x4)
- 2 – 2x4 diagonal braces (length will be determined by height of cross support)
- 4 – ½” x 10” carriage bolts with nuts and washers (9/16” holes will be drilled in support structures for these bolts)
- 16 – 2 ½” deck screws (screw 4 trimmers to 4x4)

**Components for each ramp support structure (for supporting modules less 21” high):**

- Same as above, except replace 2x4 diagonal braces with 4 – ¾” thick treated plywood gussets (gussets will be screwed to trimmer and cross supports with seven screws per gusset)
- 28 – 2 ½” deck screws (to screw gussets to 4x4)

**Construction of Support Structures (see sheet 2 drawing)**

1. During construction, we will determine the length of the 4x4s by measuring from a string line that equals the height and slope of the ramp we are building.
2. A standard guardrail height of 36” will be obtained by having 34” of 4x4 extend above the ramp surface. Compute the length of each 4x4 upright by measuring down from ramp surface to the pad on the ground and add 34” to that number.
3. The two legs are often not the same length due to uneven terrain.

4. The cross supports are extra 1/2'' longer to allow space to easily set modules in place.
5. During construction, be sure that 4x4s are plumb and cross supports are horizontal before installing carriage bolts, trimmers, gussets and bracing. Temporarily attach cross supports with screws to allow for adjustments and place bolts, bracing and gussets after all modules are in place.

### **Assembling Ramps Modules Procedures**

- Place module #1 so that 2x6 joists are 3/4'' below patio. Insure that the ramp module is level with patio (temporary support with bumper jacks in leveling module to patio).
- Run a string line from top of patio to where landing module will begin. This line represents 22% of total vertical drop. Use a line level to determine horizontal height from the patio and measure 8'' down. Bottom end of string line should be supported to this height. Match the slope of the module to this line.
- Drill three 1/2'' holes in concrete patio edge to match the 1/2'' holes pre-drilled in Module #1.
- Place 1/2'' x 3'' hex sleeve anchors in holes in concrete. Back out the bolt from the anchor, and attach to module one through pre-drilled holes. Attach nut/washer to hold module (don't tighten).
- Match module #1 slope to string line and insure module is level side-to-side. Temporary support with bumper jacks is helpful in adjusting heights.
- Place 1'x1'x3/4'' plywood pads beneath module corners and measure to top of module. Add 34'' and cut 4x4s to this length.
- Attach pads to 4x4's using 2-1/2'' deck screws, and stand in place at lower end of Module #1. Insure that 4x4's are plumb, and module is level horizontally and at proper slope (by matching to string line).
- Attach beveled cross support with screws to each 4x4 at lower end of Module #1. This will hold cross support temporarily. Trimmers and bolts will be applied at lower end of Module #1 after all modules are in place.
- At upper end of module #1, build support. Place beveled cross support tightly beneath module and screw in place. Insure 4x4's are plumb.

### **Landing Module & Right Angle Turn**

- Attach 58''x60'' landing module to bottom of Module #1 with 3/8''x 4'' carriage bolts. Support platform temporarily with jacks. Make sure the platform is level. Take measurements for length of 4x4's, and cut 4x4's to length, attach pads and place 4x4's as in sheet 2.
- Attach cross support to 4x4's with screws on opposite side of landing

### **Remaining Ramp Modules**

- Attach string line from top of level landing to point where ramp will end and attach Module #2.

- Attach Module #2 to landing with 3/8'' x 4'' bolts and tighten firmly. Support lower end of Module #2 with jacks and match slope to sting line. Cut 4x4's to length, stand in place at lower end of Module #2, and attach cross supports with screws.
- At top of Module #2, attach cross support to 4x4's with screws.
- Repeat process to add Module #3 and #4.

### **Transition from ramp to ground**

Working over concrete sidewalk, Module #4 four joists are cut to taper that matches the ground level. An end piece is attached to these four joists, and this is bolted into place in the same manner as the module.

An outrigger is placed underneath Modules #4. The 4x4 posts are braced using this outrigger (see sheet 2). Cut a deck board with a bevel to provide a smooth transition from end of ramp to the hard surface.

To construct outrigger, cut a 1 1/2'' x 3 1/2'' notch in each outside joist, near the end of modules #4. Place a 26'' long 2x4 through this notch and attach to inside joist. Stand 4x4 in place and cut a 15'' long brace with a 45-degree angle cut on each end using 4x4's. Attach this brace with screws to the upright 4x4 and the horizontal 2x4. See sheet 2.

### **Complete Construction of Support Structure**

With all the modules attached and in place, post plumb, and modules level, complete construction of support structures.

Cut 2x4 diagonal braces lengths determined by height of cross support.

Cut 2x4 trimmer lengths determined by height of cross support.

Drill four - 9/16'' holes in support structure for 1/2''-10'' carriage bolts. Attached carriage bolts through cross pieces and diagonal braces.

Attach trimmer to 4x4 with 3'' deck screws.

### **Decking**

Decking will be attached after module frames and landing module are placed in the ramp and support structures are completed. Decking adds significant weight to module. Place 1/8'' gaps between decking boards to allow for drainage. Use two deck screws in each plank at each joist.

### **Installing Guardrail/handrail**

Attach 2x4 boards to 4'' x 4''s parallel to ramp surface, 2'' above ramp surface.

Attach 2x6 boards parallel to 2x4's so that top of 2x6 is 36'' above ramp.

Cut 2x2 spindles to 30'' lengths and attach vertically to 2x4 and 2x6's with 4'' space between each. Use a 3 7/8'' space to make spindles installation easier.

1-1/2'' PVC pipe will be used as hand rails. Hand rail brackets will be attached to the 4x4's at 30'' height. The PVC pipe will be attached to the hand rail brackets. The hand rail will be installed on one side (only). PVC elbows will be used on the ends to form a return.

### **Porch railing**

A six foot section of railing/fence will be built to match the existing porch railing construction to cover that portion where the existing steps are currently. Construction includes 4x4'' posts connected with 2x4'' railings. White plastic lattice will be added onto this as well. The railing will be painted white.

## **Financial Plan**

Total cost of the project excluding donations will be \$1,459.

The church is not going to pay for this project from general funds.

I will ask for donations from the church congregation by making a flyer and putting it in the church bulletin.

I will ask for donations from the company EMC Engineers, Inc.

Also, contractors that are members of the church congregation will be asked to donate materials.

I am going to write my relatives asking for donations.

Finally, donations will be asked from the architect's company who is helping approve of this project.

I plan to raise the money in its entirety before I begin the project. If I don't raise the total amount for the project, I will review the scope of the project with the church, my unit, and the district eagle board. There may be less expensive construction methods and materials that I can use as an option B if I cannot raise enough money to satisfy the proposed budget.

## **Schedule**

This project will be done in phases with multiple steps in each phase. My proposed schedule for the project is:

- 1) Fund raising, start as soon as possible, after the approval of the project.
- 2) Purchase materials and site mobilization – Prior to work day 1
- 3) Assembly of ramp modules and assembly of landing module, and demolition of existing landscaping and porch railing – Work day 1
- 4) Assembly of support structures and assembling the modules into ramps – Work day 2
- 5) Installing decking, rails, railing pickets, and replacement railing – Work day 3

## **Written/Printed Information**

I am going to make a flyer announcing my workdays for the project. I am also going to make an insert that is going in the church bulletin asking for donations for the project.

## **Helpers / Workers**

The workers for this project will be members of troop 714 along with volunteers from my high school marching band and church youth group. The project will be broken down into 5 different phases:

- 1) Fund raising
- 2) Purchase materials and site mobilization
- 3) Assembly of ramp modules, assembly of landing module, and demolition
- 4) Assembly of support structures and assembling the modules into ramps
- 5) Install decking, rails, railing pickets, and replacement railing

## **Fund raising**

I will write a flyer asking for donations from the church congregation, which will be placed in the Sunday bulletin at each church service. I will also ask the contractors in the church congregation if they have any excess materials they wish to be donated to the project. In addition to asking donations of the church congregation, I will write a letter to the president of EMC Engineers, Inc., an Eagle Scout himself, asking whether he would also like to donate any money towards the completion of this project. I will ask friends and relatives to donate to the project. Finally, I will ask for donations from the firm of the architect who is helping approve that my project stays within city code.

<b>Action</b>	<b>No. of Youth</b>	<b>Hours per youth</b>	<b>Total Youth Hours</b>	<b>No. of Adults</b>	<b>Hours per adult</b>	<b>Total adult hours</b>

Write a letter asking for donations from the church congregation & ask the contractors from the church congregation if they are willing to donate any extra materials to the project.	1	4	4			
Contact EMC & relatives for donations	1	5	5	0	0	0
Contact architectural firm for donation	1	1	1	0	0	0
<b>TOTAL</b>		<b>Total youth hours</b>	<b>10</b>		<b>Total adult hours</b>	<b>0</b>

### **Purchase Materials and Site Mobilization**

Buy materials from Home Depot, and move them to the work site. This will only require the help of a couple of other people along with myself.

<b>Action</b>	<b>No. of Youth</b>	<b>Hours per youth</b>	<b>Total Youth Hours</b>	<b>No. of Adults</b>	<b>Hours per adult</b>	<b>Total adult hours</b>
Buy materials from Home Depot	1	3	3	1	3	3
Haul materials to the worksite (the church)	2	2	4	2	2	4
<b>TOTAL</b>		<b>Total youth hours</b>	<b>7</b>		<b>Total adult hours</b>	<b>7</b>

### **Work Day 1 - Assembly of ramp modules, assembly of landing module, and demolition**

I am going to build 4 ramp modules, and 1 landing module. I will also have to remove excess landscaping and porch railing that is currently in the way of the ramp project. This will be a 6 hour work day.

<b>Action</b>	<b>No. of Youth</b>	<b>Hours per youth</b>	<b>Total Youth Hours</b>	<b>No. of Adults</b>	<b>Hours per adult</b>	<b>Total adult hours</b>
Cut Lumber	1	2	2	1	2	2
Assemble ramp modules	10	3	30	2	3	6

Assemble landing module	3	2	6	1	2	2
Remove landscaping and portion of existing porch railing	2	2	4			2
				1	2	
<b>TOTAL</b>		<b>Total youth hours</b>	<b>42</b>		<b>Total adult hours</b>	<b>12</b>

### **Work Day 2 - Assembly of support structures and assembling the modules into ramps**

I will have a couple of people cutting the necessary lengths for the support structures from the supply of lumber, while other people are assembling the already constructed modules into the ramp itself. This will be a 6 hour work day

<b>Action</b>	<b>No. of Youth</b>	<b>Hours per youth</b>	<b>Total Youth Hours</b>	<b>No. of Adults</b>	<b>Hours per adult</b>	<b>Total adult hours</b>
Cut Lumber	1	2	2	1	2	2
Assemble modules into ramps	5	4	20	2	4	8
Assemble support structures	4	4	16	2	4	8
Assembl transition to sidewalk	2	2	4	1	2	2
<b>TOTAL</b>		<b>Total youth hours</b>	<b>42</b>		<b>Total adult hours</b>	<b>20</b>

### **Work Day 3 - Installing decking, railing, railing pickets, and porch railing**

People will nail down the decking that completes each module. The railing for the ramp will be completed during this phase, and the railing pickets will also be during this final stage of the project. A new section of railing will be installed on the existing porch. This will be a 5 hour work day.

<b>Action</b>	<b>No. of Youth</b>	<b>Hours per youth</b>	<b>Total Youth Hours</b>	<b>No. of Adults</b>	<b>Hours per adult</b>	<b>Total adult hours</b>
Cut Lumber	1	2	2	1	2	2

Install decking	3	4	12	1	4	4
Install railing	2	3	6	1	3	3
Install pickets	3	4	12	1	4	4
Install replacement porch	2	3	6	1	3	3
			0			0
<b>TOTAL</b>		<b>Total youth hours</b>	<b>38</b>		<b>Total adult hours</b>	<b>16</b>

### Total Estimated man-hours for project

Action			Total Youth Hours			Total adult hours
Fund raising			10			0
Purchase materials and site mobilization			7			7
Work day 1 - Assembly of ramp modules, assembly of landing modules, and demolition			42			12
Work day 2 - Assembly of support structures and assemble the modules into ramps			42			20
Work day 3 - Installing decking, railing, railing pickets, and porch railing			38			16
			0			0
<b>TOTAL</b>		<b>Total youth hours</b>	<b>139</b>		<b>Total adult hours</b>	<b>55</b>

### Adult Supervision

I will make sure I will always have at least two adults while working on any construction phase of my project. At least one adult will have youth protection training.

## **Work Site**

All construction work will be done at the site of the Church where the project is going to be placed.

## **Transportation**

All work will be done at the location listed above. The workers will be expected to find their own transportation to the work sites. If a problem should arise, arrangements will be made to get the worker to the needed work site.

## **Safety**

During my project I will follow the *Guide to Safe Scouting*. I will have proper instruction and supervision of power tool use. I will have appropriate safety equipment, such as safety goggles, gloves etc. I will always make sure that there is a first aid kit ready and available on the work site. We will be using circular saws. I will make sure that only older scouts use power saws while under adult supervision.

## Approval Signatures for Project Plan

Project plans were reviewed and approved by

\_\_\_\_\_  
Religious institution, school, or community representative      Date

\_\_\_\_\_  
Scoutmaster/Coach/Advisor      Date

\_\_\_\_\_  
Unit Committee member      Date

\_\_\_\_\_  
Council or district advancement committee member      Date

## Attachment A – Pictures of Existing Conditions



Picture 1 - Brick Steps leading from sidewalk to porch



Picture 2 - Sidewalk leading up to brick stairs



Picture 3 - Sidewalk leading up to brick stairway



Picture 4 - Existing railing around porch and stairs

## **Attachment B – Construction Drawings**

See attached drawings:

Sheet 1 - framing plan - for a layout of the ramp modules and ramp railing design; and location of new porch railing.

Sheet 2 – support plan - for supports used to hold up the ramp modules, plus design of railings

# Handicap Ramp Donations

Christ United Methodist Church

Roswell, Georgia

Justin Lundstrom has proposed to build a handicap access ramp to the front of the church office as part of a Boy Scout Eagle Project. The church does not have money to fund the project. Justin is requesting donations for this project from church members and friends. If you would like to donate to the project, please write a check to Christ UMC, and note "Eagle Project Donation-Ramp" on your check. Thank you for your consideration of this needed project.

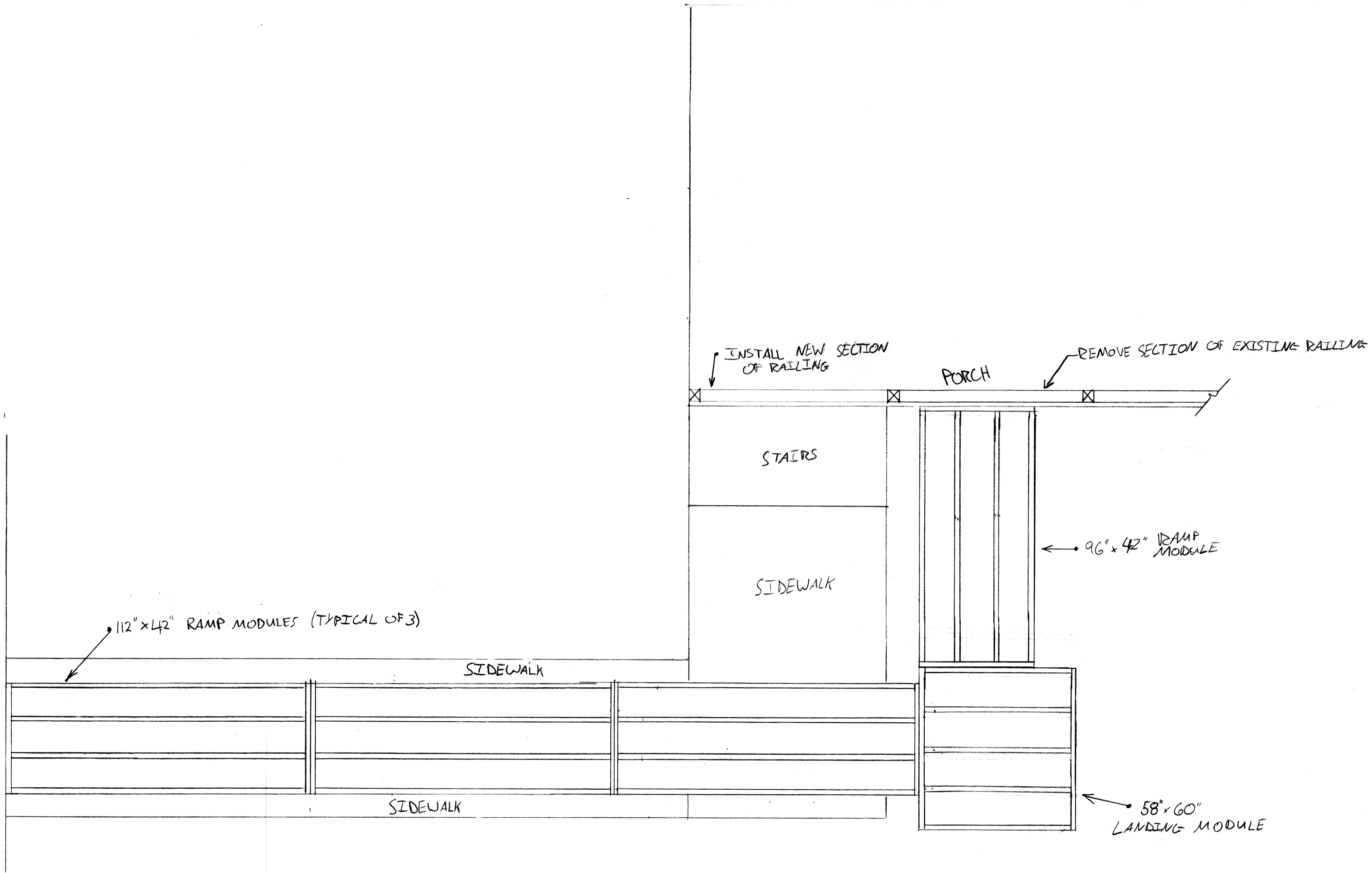

FRAMING PLAN  
 1/2" = 1'-0"

FRAMING PLAN		
SCALE: 1/2" = 1'-0"	APPROVED BY:	DRAWN BY: LUNDSTROM
DATE: 12-5-2008		REVISED:
CHRIST UMC - RAMP		
DRAWING NUMBER		1

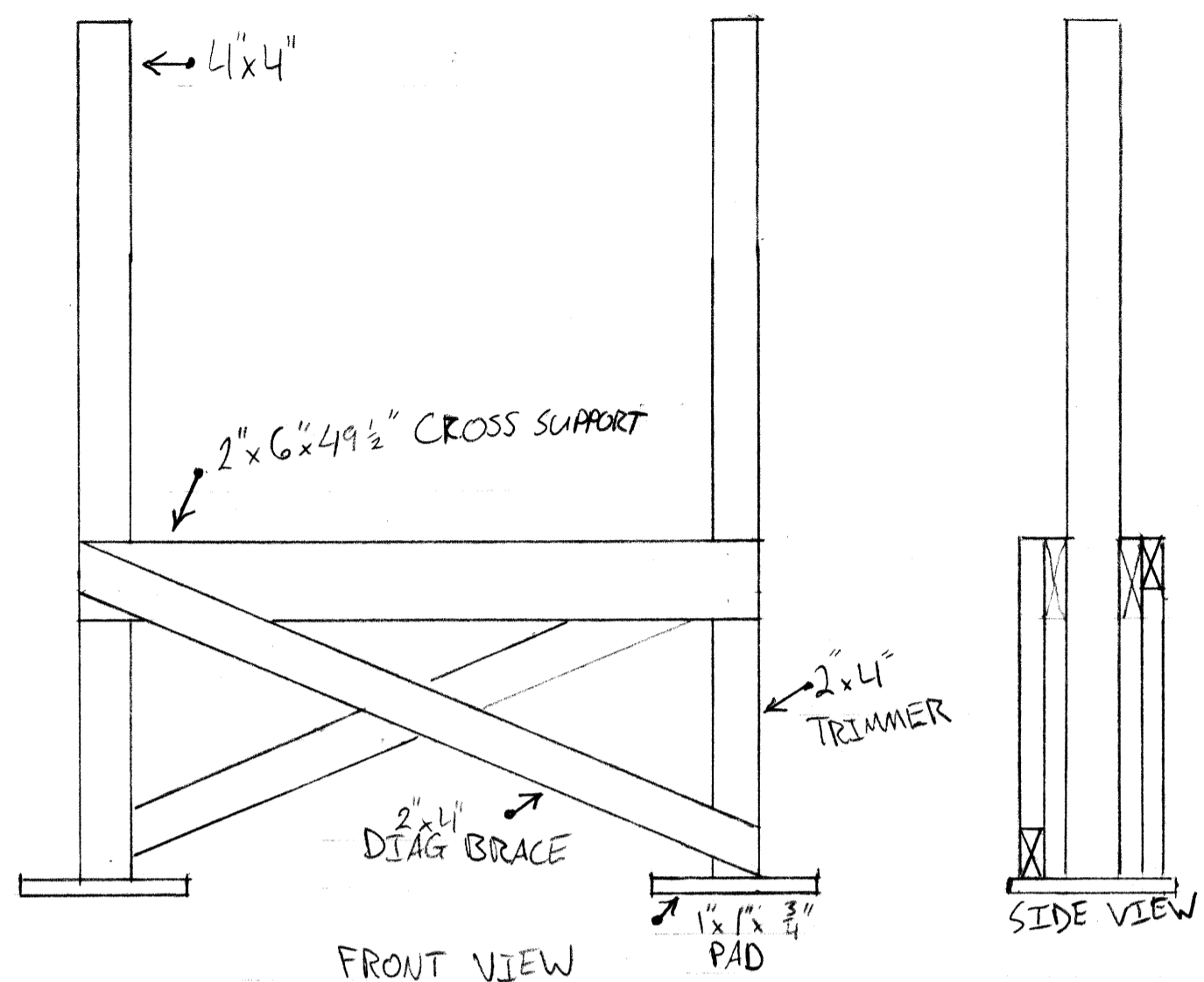

DETAIL A - SUPPORT STRUCTURE  
SCALE 1" = 1'-0"

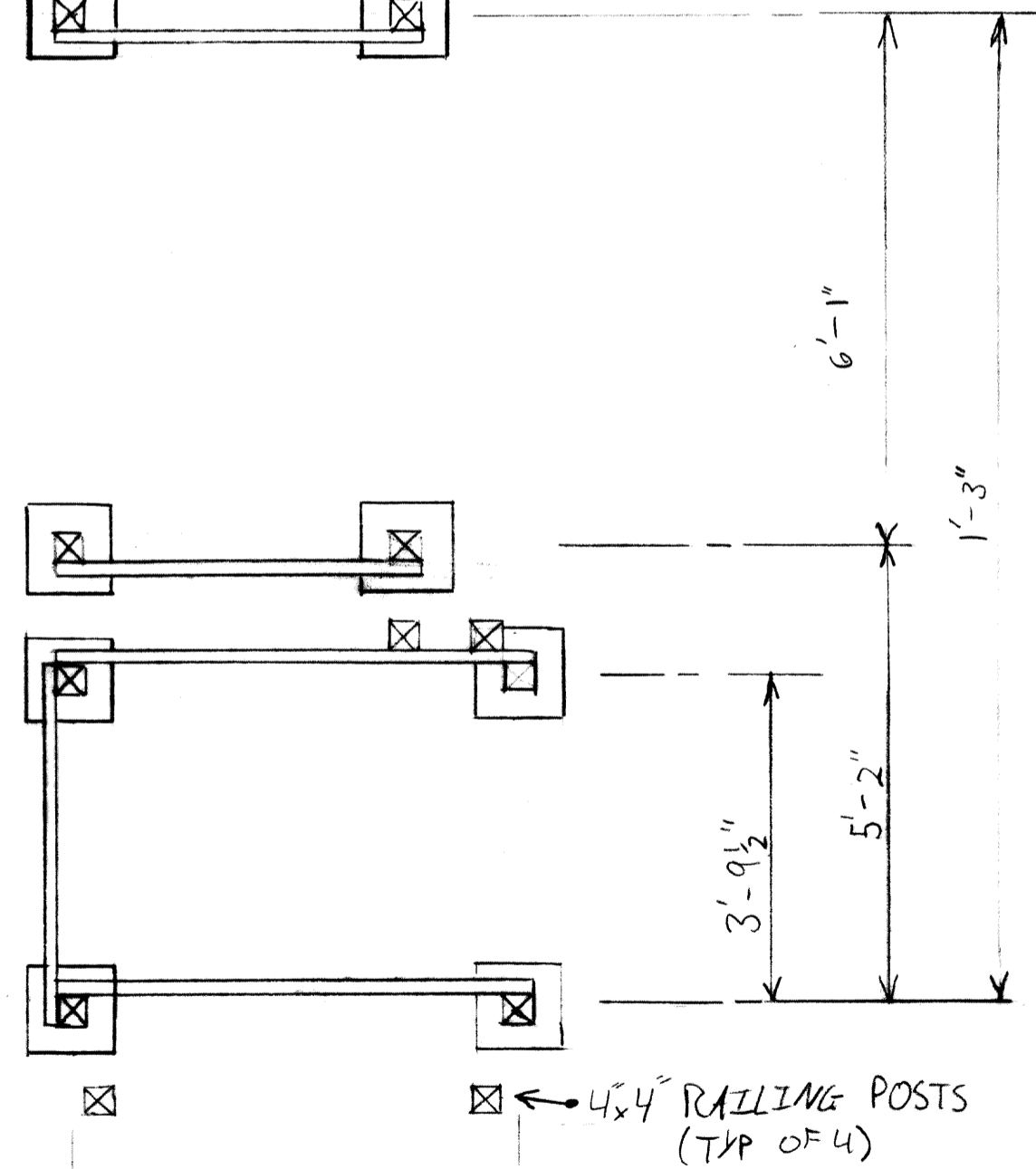
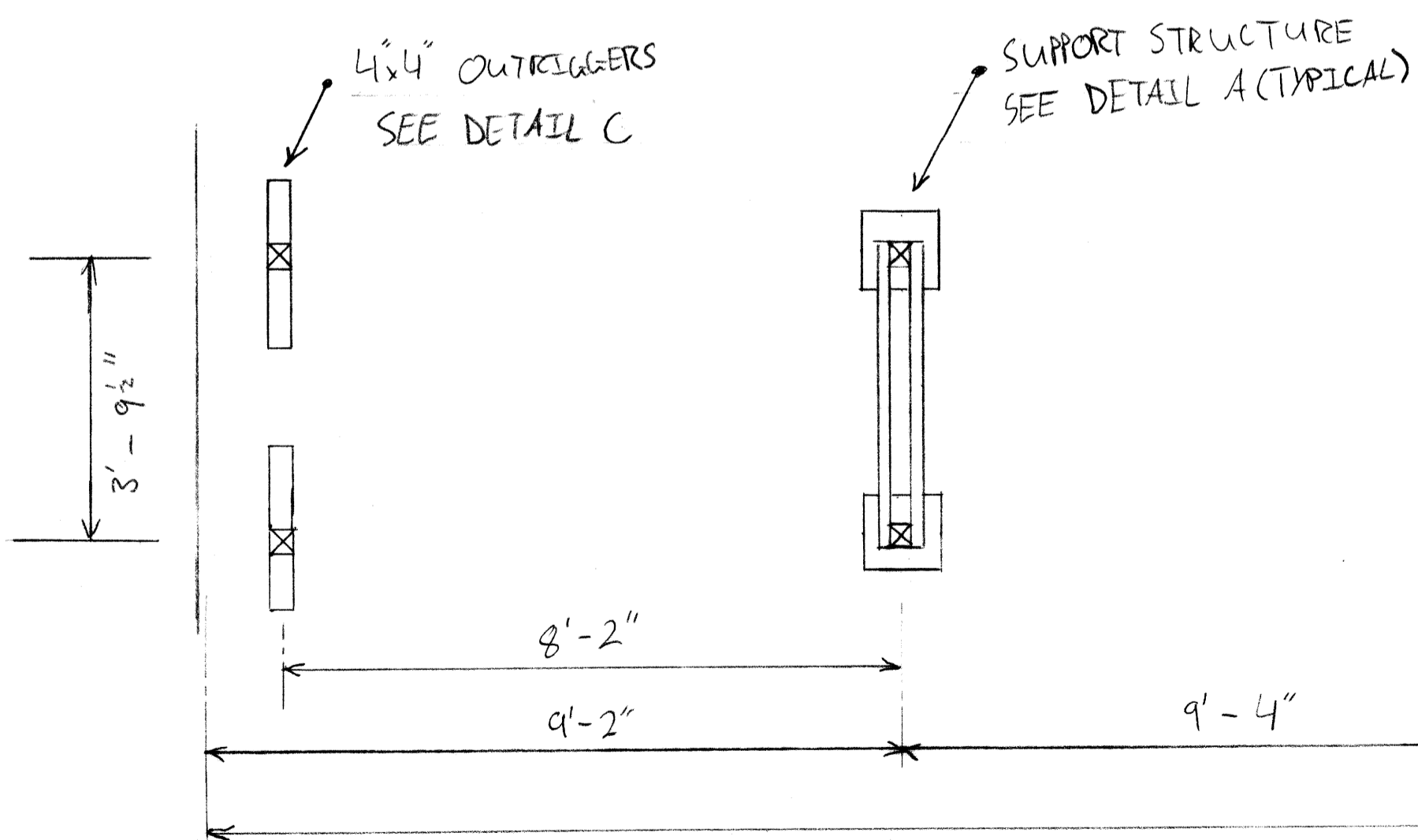
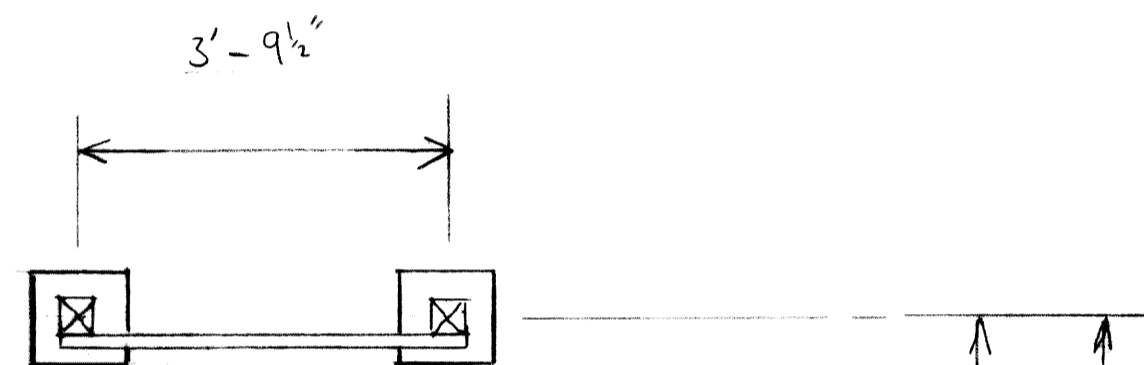
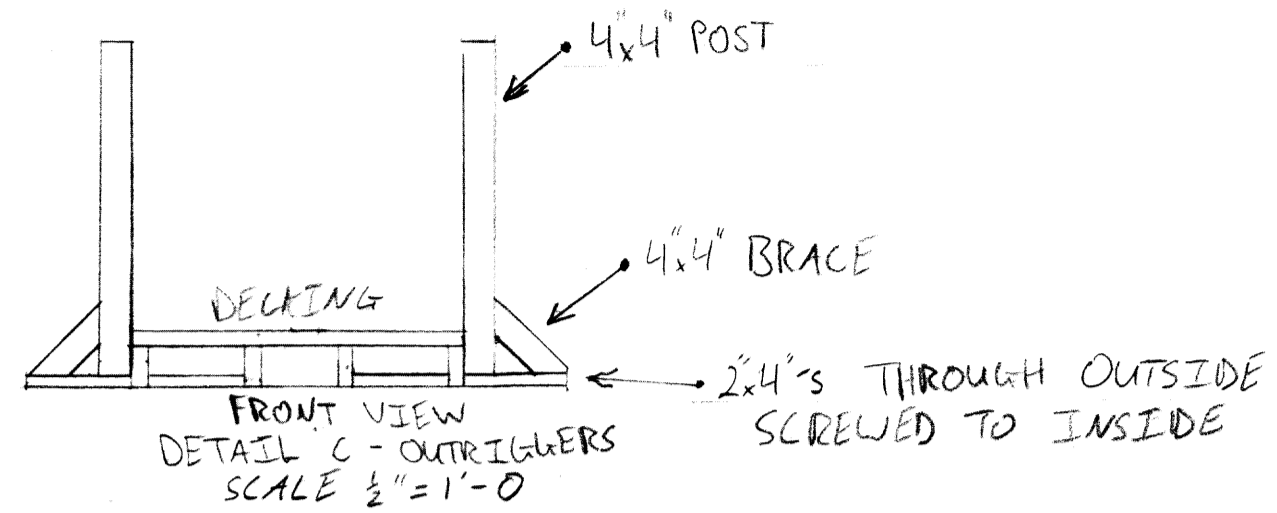
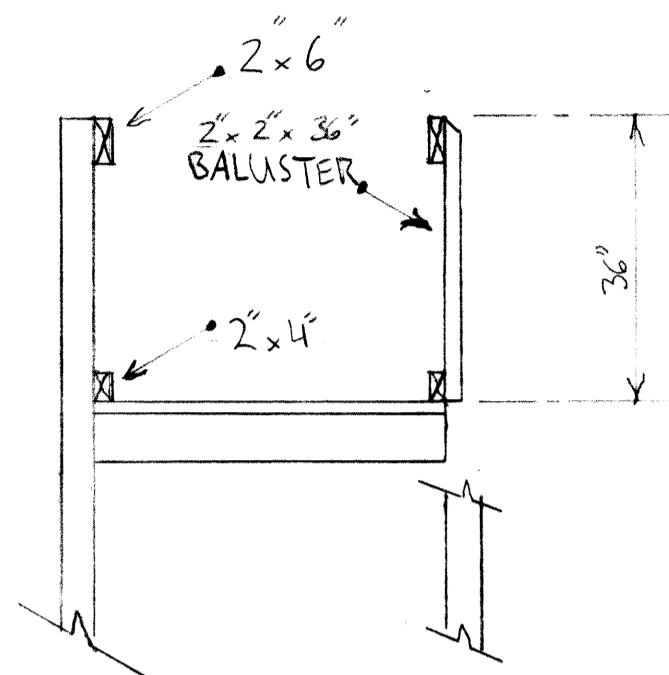

STRUCTURE PLAN		
SCALE: 1/2" = 1'-0"	APPROVED BY:	DRAWN BY: LUNDSTROM
DATE: 12-5-2008		REVISED:
CHRIST UMC - RAMP		
		DRAWING NUMBER 2